

An Experimental investigation on Feature Extraction and Fault Detection in Analog circuits using Fuzzy logic and Neural Network

B Rebecca ¹, P Sumathi ², M Beulah Viji Christiana ³, A Sanjeevi Gandhi ⁴, G S Raghavendra ⁵, D. Rosy Salomi Victoria ⁶, Thiyagesan M ⁷, Y. Sherlin Nisha ⁸

¹ Department of Computer Science and Engineering, Marri Laxman Reddy Institute of Technology and Management.

² Department of Computer Science and Engineering, Sri Sairam College of Engineering, Bengaluru, Karnataka.

³ Department of Master of Business Administration, Panimalar Engineering College, Chennai.

⁴ Department of Electrical and Electronics Engineering, Sri Sairam Engineering College, Chennai.

⁵ Department of Computer Science and Engineering, Koneru Lakshmaiah Education Foundation, Hyderabad.

⁶ Department of Information Technology, Chennai Institute of Technology, Chennai, Tamil Nadu 600069.

⁷ Department of Electrical and Electronics Engineering, R.M.K Engineering College, Kavaraipettai, Chennai.

⁸ Department of Mathematics, Sri Sairam Institute of Technology, Chennai, Tamil Nadu 600044, India.

Corresponding Author Email: drbright.sa@gmail.com

<https://doi.org/10.14447/jnmes.v28i1.a04>

ABSTRACT

Received: April 09-2024

Accepted: December 20-2024

Keywords:

key word 1, key word 2, key word 3, key word 4, key word 5, key word 6, key word 7, key word 8

(no more than 8 keywords)

This paper introduces an innovative approach to enhance feature selection and enable dual fault diagnosis in analog circuits. By harnessing the combined power of fuzzy logic and neural networks, this study presents a robust framework for precisely pinpointing faults within the circuit. The operational integrity of any circuit hinges upon its inherent parameters, and the presence of defective components within the circuit distorts its performance, resulting in output deviations. The techniques elucidated in this research not only identify the specific faulty component but also quantify the extent of its deviation from the original parameters. A comparative analysis between the efficacy of fuzzy logic and neural networks in addressing this challenge is expounded upon. To demonstrate the practical application of these methodologies, a Sallen-key Bandpass filter is employed as the circuit under scrutiny (CUT). A comprehensive fault dictionary, constructed via the extraction of pertinent features from the CUT, serves as the cornerstone of this study. Notably, the fault table is meticulously generated, utilizing a step size of +/- 5% for parameter value perturbation.

1. INTRODUCTION

Since Early 1970s, fault detection in analog circuit has become one of the important research area in electronic testing. The rapid development in electronic sector paved way for various research areas in that domain [1- 3]. Fault identification and detection in analog circuits is an interesting area where researchers are working. Many fault models have been proposed and tested throughout the years. The fault diagnosis method gradually starts to improve over the years with the help of soft computing techniques and heuristic algorithms [4]. Simulation based fault diagnosis method broadly classified into to types. Simulation Before Test (SBT) and Simulation After Test (SAT) are the two different models of fault diagnosis method which is commonly used in analog circuit fault detection. In SBT, a fault dictionary has been created and soft computing logics are used to find the faults [5,6]. In SAT, parameter identification methods can be used to locate the fault. The disadvantage of this method is that it increases the time spent on diagnosis at the production time Parametric components of the circuit determines the functionality of the circuit and the presence of the faulty component where the values of those components changes

beyond a limit then it affects the circuit performance [7]. So there is a need to identify the faults present in the circuit and also its deviation from the original value. Data extraction is the key for any fault diagnosis method in analog circuits. Frequency, Gain, phase margin, Gain margin, Magnitude, poles and zeroes are some of the important features that can be extracted from the filter circuit [5]. Based on the characteristics of these features, a suitable fault diagnosis method can be employed. Fault classification heavily depends on soft computing techniques such as fuzzy logic, Neural networks, Genetic algorithm and so on [8-10]. In fault dictionary method, the CUT is simulated under different fault conditions and its performance is monitored with selected features. These features are extracted and tabulated for both fault free and faulty conditions. Applications of fuzzy logic has been increased in the recent years over a wide range of electronic products. The use of multivalued logic is the key success behind the fuzzy logic. On the other hand neural network trains the system to predict the output.

2. PROPOSED METHOD

The CUT used in this work is the Sallen-key band pass filter. By using the transfer function of filter, we can extract some features of the circuit, such as gain margin, poles and zeroes and frequency... Based on the characteristics of the feature extracted, fault classification methods can be selected. Double faults are used to create the fault table. In single faults, value of any one particular component is changed at a time. Whereas in double fault values of two components are changed at a time. The feature extracted from the transfer function in this work is the value of the poles. The work flow of the proposed method is shown in Figure 1.

The CUT is simulated under fault-free conditions and its performance has to be tabulated; then faults have to be induced in the circuit by gradually varying the components value in the filter. After changing the component's value, the circuit has to be simulated, and its performance has to be tabulated. A fault dictionary is created by repeating the above process for all the components.

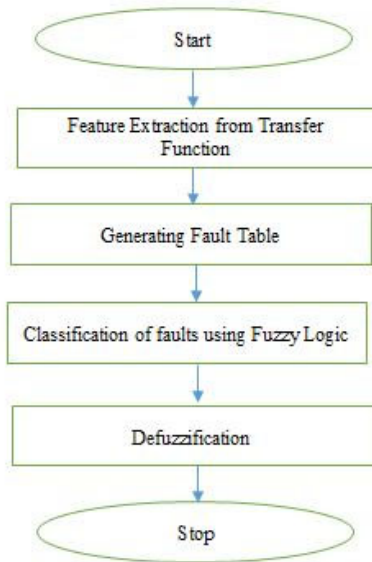

Figure 1. Working method of the proposed system with fuzzy logic

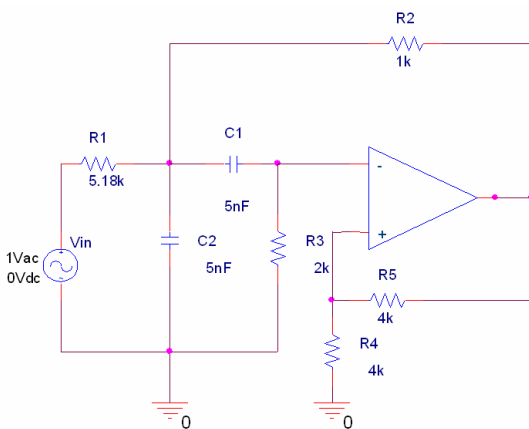

Figure 2 Sallen-key Bandpass filter

FIS is used to classify the faults; triangular membership function is selected in this method for its simplicity. Figure 2 shows the Sallen-Key Bandpass filter, a Voltage-Controlled

Voltage-Source (VCVS) filter topology. sallen-key Bandpass filter is used as the CUT in this work because of its simple design with high input impedance and an easily selectable gain.

Transfer function of the filter is

$$G(s) = \frac{SA_0G_1C_1}{S^2C_1C_2 + S(G_3C_1 + G_3C_2 + G_1C_1 + C_1G_2(1-A_0)) + G_3(G_1 + G_2)}$$

2.1 Feature Extraction

Before creating a fault table, feature extraction is very important. In parametric fault detection using the transfer function, one can extract many features such as gain, phase margin, frequency, poles and zeroes is shown in Figure 3. Based on the method used to classify the fault, features are selected. In this paper, poles and zeroes are extracted from the transfer function for each fault.

Table 2. Fault table for R3 & C1

Fault	R1	C1 x10 ⁹	IP1	IP2	Fault Index
-50	2590	2.5	-88610	218156.5	38
-40	3108	3.0	-65508.4	199416.6	39
-30	3626	3.5	-49007.2	184524.6	40
-20	4144	4.0	-36631.3	172310.7	41
-10	4662	4.5	-27005.6	162048.1	42
FF	5180	5.0	-19305	153259	NA
10	5698	5.5	-13004.6	145614.6	43
20	6216	6.0	-7754.18	138880.5	44
30	6734	6.5	-3311.55	132884.4	45
40	7252	7.0	496.4148	127496.5	46

Fault	R3	C1x10 ⁹	IP1	IP2	Fault Index
-50	1000	2.5	-219305	217599	11
-40	1200	3.0	-141527	215059.5	12
-30	1400	3.5	-92774.4	200222	13
-20	1600	4.0	-59930	183551.7	14
-10	1800	4.5	-36589	167688	15
FF	2000	5.0	-19305	153259	NA
10	2200	5.5	-6081.88	140295.6	16
20	2400	6.0	4306.092	128653	17
30	2600	6.5	12647.64	118148.1	18
40	2800	7.0	19470.49	108604.2	19

Table 3. Fault table for R3 & C2

Fault	R2	C2x10 ⁹	IP1	IP2	Fault Index
-50	2590	2.5	-27220.1	233886.9	29
-40	3108	3.0	-20291.7	208917.7	30
-30	3626	3.5	-17969.4	190074	31
-20	4144	4.0	-17664.1	175273.5	32
-10	4662	4.5	-18277.8	163263	33
FF	5180	5.0	-19305	153259	NA
10	5698	5.5	-20500	144749.7	34
20	6216	6.0	-21739.6	137387.4	35
30	6734	6.5	-22961.5	130927.5	36
40	7252	7.0	-24135.2	125192.3	37

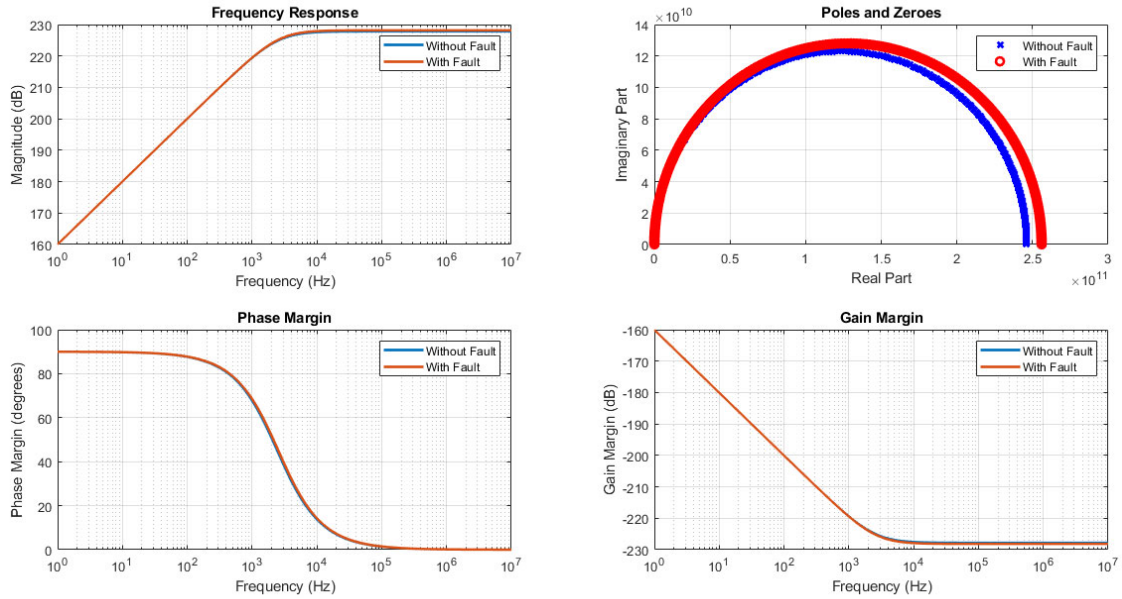

Figure 3. Various features extracted for both faulty and non-fault conditions of sallen-key band pass filter

Fault table is created by introducing the faults and tabulating their response. In this paper, double faults are introduced, and the corresponding poles and zeros values

Table 1 shows the Fault index value with corresponding fault conditions of R1 and R2. Similarly Table 2 shows the fault condition of components R3 and C1 and Table 3 shows the fault conditions of R3 and C2, Table 4 shows the fault condition of R2 and C2 and Table 5 shows the fault condition of R1 and C1 with corresponding fault index values are tabulated. The step size for each fault is 10% of the original value of the components. This step size covers from -50% to +50% for the actual value of the component.

Table 4. Fault table for R² & C²

Fault	R1	R2	Poles(Real)	Poles (Imaginary)	Fault Index
-50	2590	500	61389.96	209650.4	1
-40	3108	600	34491.63	196414.5	2
-30	3626	700	15278.54	183993.8	3
-20	4144	800	868.7259	172700.6	4
-10	4662	900	-10338.9	162497.2	5
FF	5180	1000	-19305	153259	NA
10	5698	1100	-26640.9	144851.9	6
20	6216	1200	-32754.2	137154.4	7
0	6734	1300	-37926.9	130062.2	8
40	7252	1400	-42360.7	123487.4	9
50	7770	1500	-46203.3	117356.7	10

2.3 Fault Classification

Fuzzy logic has been used to classify the faults. Once the fault table has been generated, based on the fault index and the feature that has been extracted, a suitable fault classification method has to be employed. For double faults with poles and zeros as features extracted from the transfer function, fuzzy

logic is the suitable method for fault classification. In fuzzy logic, there are two types: Mamdani FIS and Sugeno FIS, in this paper, for fault classification Mamdani FIS is used. Figure 5 Shows the membership function of the proposed method.

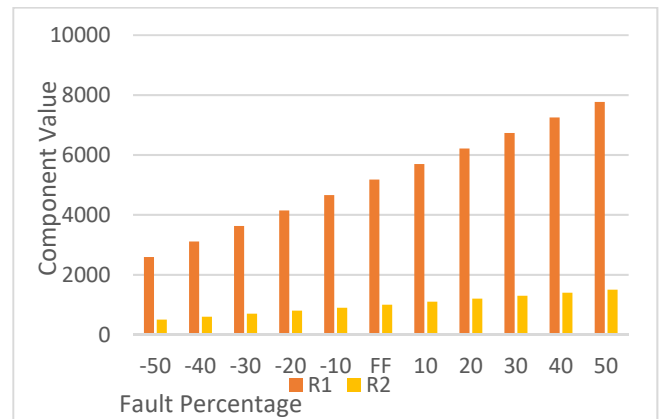

Figure 4. Fault Percentage of R1 and R2 from Table 1

Figure 4 shows the fault percentage of R1 and R2 from Table 1. Value of R1 and R2 is changed from -50% to +50%.

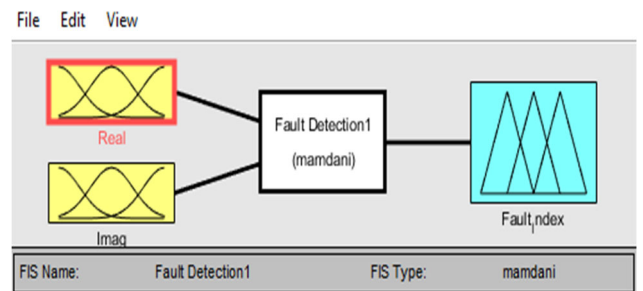

Figure 5. FIS of the proposed system

Table 5. Fault table for R1 & C1

Fault	R3	C2x10 ⁹	IP1	IP2	Fault Index
-50	1000	2.5	-138610	276100.1	20
-40	1200	3.0	-87730.6	242041.1	21
-30	1400	3.5	-58190.8	212860.9	22
-20	1600	4.0	-39756.3	188950.4	23
-10	1800	4.5	-27622.9	169396	24
FF	2000	5.0	-19305	153259	NA
10	2200	5.5	-13417.8	139784.8	25
20	2400	6.0	-9143.07	128399.9	26
30	2600	6.5	-5974.28	118672.8	27
40	2800	7.0	-3585.22	110277.5	28

2.4 Fuzzy Inference System

Once the fault table has been generated successfully, a suitable fault classification method needs to be used. In this paper, Mamdani FIS is used to classify the faults because there is no linear relationship between the inputs and outputs. In the FIS Membership function, the number of inputs is selected based on the feature extracted from the transfer function. In this work, poles are extracted from the transfer function and fault dictionary is created with the values of poles which is a complex number with a real and imaginary part. Figure 6 shows the fuzzy membership functions of the proposed model.

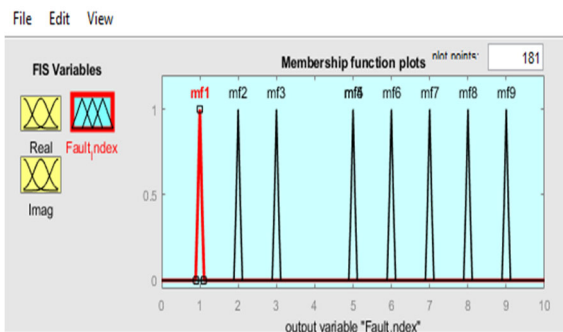

Figure 6. Fuzzy Membership functions

2.5 Fuzzy Rule Set

????? are tabulated. The step size for each fault is 10% of the original value of the components. This step size covers from -50% to +50% for the actual value of the component. For inputs and outputs, corresponding membership functions can be selected and connected either using OR operator or AND operator. AND operator is used as a connector. If (MF1 - input) and (MF2 - input) then (MF - output).

2.6 Neural Network

Unlike fuzzy, a Neural network can predict the fault by training the network with the values from fault dictionary. This process of selecting the inputs from a dataset and mapping it to the desired output is called neural fitting.

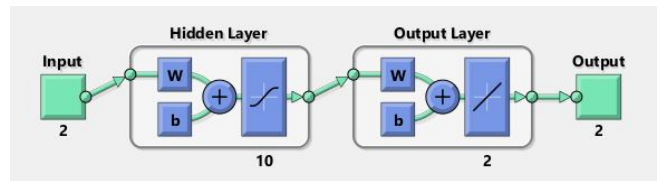

Figure 7. Neural network model

3. EXPERIMENTAL RESULTS

Once the dataset is mapped with the target output network can be trained and evaluated to measure its performance using mean square error and regression analysis. Fault detection using fuzzy logic entirely depends on its fault dictionary; in this work, complete dependency of a fault dictionary to identify the fault has been overcome with the help of neural network. Sample data from fault dictionary has been trained with the neural network, new faults have been tested, and its performance is tabulated. A two-layer feed-forward network with sigmoid hidden neurons and output. Fault detection is done by training the neural network with the fault dictionary. Fault dictionary is created by injecting the faults in the circuit by varying the component values. A set of values from the fault dictionary is used to train the network. Levenberg – Marquardt backpropagation algorithm is used to train the network. Figure 7 shows the proposed neural network model used in the proposed system.

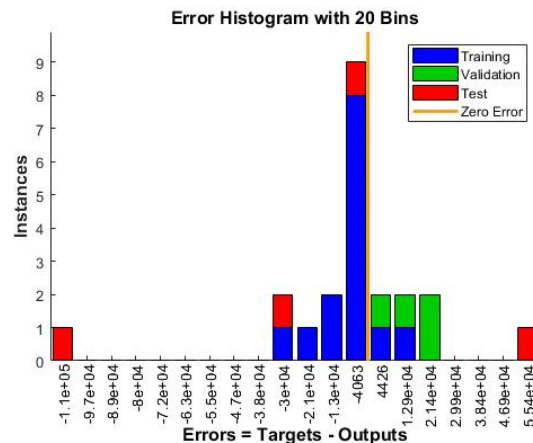

Figure 8. Error histogram

Figure 8 shows the error histogram of the trained network. It is the difference between the target value and the predicted value of the network after it has been trained. These values show how far the predicted value differs from the target value.

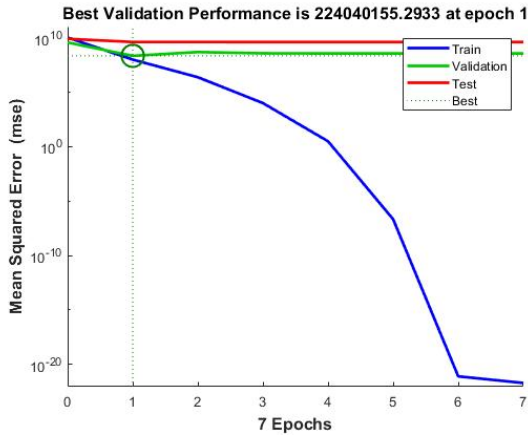

Figure 9. Best Validation performance of the network.

The best validation performance of a neural network shows at which iteration the network can provide the best result. Figure 9 shows the best performance of the network has happened at the first iteration itself. Training state of the network is shown in Figure 10.

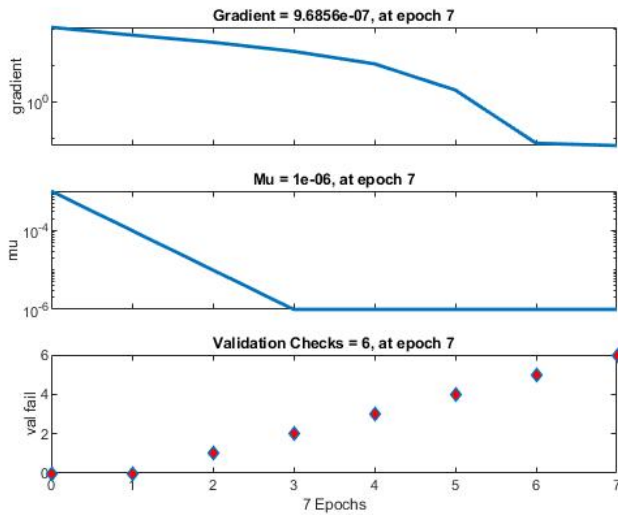

Figure 10. Training state of the network

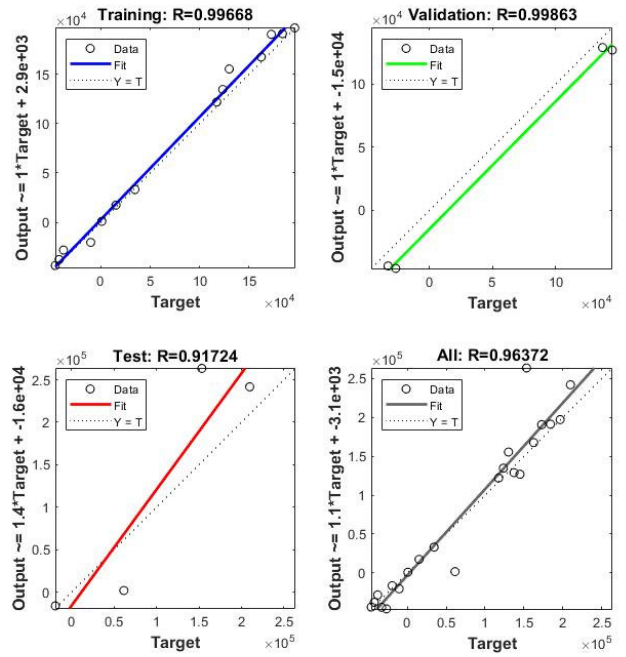

Figure 11. Regression

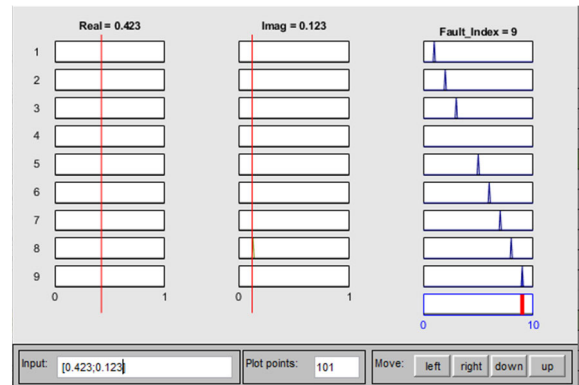

Figure 12. Fuzzy Rule Viewer

Figure 11 shows the regression analysis of the proposed method and Figure 12 shows the output of the fuzzy logic; fault index for the respective input is 9; from the fault table, it is clear that the fault is located in R1 and R2, where both the values of the resistors deviated from their original value from +40%.

4. CONCLUSION

Based on the fault table, the values are processed using fuzzy logic. Figure 11, shows the rule viewer of the FIS, where pole values from table 1 are entered and their corresponding fault index value is reflected in the rule viewer. Using fuzzy logic, faults are classified, and can be located. The components can be identified with respect to the fault index and how much its value has been deviated from its original value can also be identified. For this problem, Fuzzy logic entirely depends on the fault dictionary; fuzzy cannot locate a fault that is not present in the fault dictionary. In a Neural network, fault dictionary values are trained, and can predict new faults. For the neural network model proposed in the paper, the best validation occurred at the first epoch itself. However, the

anticipated model can be improved by analyzing various fault models and optimization algorithms.

Conflicts of interest

I hereby declare that NO affiliations involvement in any organization or entity with any financial interest or non-financial interest in the subject matter or materials discussed in this manuscript. This manuscript work was solely done by the author under the guidelines of the supervisor Dr. K. Kavitha.

Data Availability

Data sharing not applicable to this article as no datasets were generated or analyzed during the current study.

REFERENCES

- [1] Y. Yu, Y. Jiang, and X. Peng, "Multi-frequency test generation for incipient faults in analog circuits based on the aliasing measuring model," *IEEE Access*, vol. 6, pp. 34724–34735, 2018.
- [2] H. Lei and K. Qin, "A general method for analog test point selection using multi-frequency analysis," *Analog Integr. Circuits Signal Process.*, vol. 84, no. 2, pp. 185–200, Aug. 2015.
- [3] Y. Xie, X. Li, S. Xie, X. Xie, and Q. Zhou, "Soft fault diagnosis of analog circuits via frequency response function measurements," *J. Electron. Testing*, vol. 30, no. 2, pp. 243–249, 2014.
- [4] J. J. Saucedo-Dorantes, M. Delgado-Prieto, R. A. Osornio-Rios, and R. de Jesus Romero-Troncoso, "Multifault diagnosis method applied to an electric machine based on high-dimensional feature reduction," *IEEE Trans. Ind. Appl.*, vol. 53, no. 3, pp. 3086–3097, May/Jun. 2017.
- [5] L. Xu, M. Cao, B. Song, J. Zhang, Y. Liu, and F. E. Alsaadi, "Opencircuit fault diagnosis of power rectifier using sparse autoencoder based deep neural network," *Neurocomputing*, vol. 311, pp. 1–10, Oct. 2018.
- [6] Y. Han, B. Tang, L. Deng, "Multi-level wavelet packet fusion in dynamic ensemble convolutional neural network for fault diagnosis," *Measurement*, vol. 127, pp. 246–255, Oct. 2018.
- [7] Z. Liu, Z. Jia, C.-M. Vong, S. Bu, and J. Han, "Capturing highdiscriminative fault features for electronics-rich analog system via deep learning," *IEEE Trans. Ind. Informat.*, vol. 13, no. 3, pp. 1213–1226, Jun. 2017.
- [8] L. Penghua, C. Yi, C. Ming, Q. Yife ng, and Z. Ke, "Multiple fault diagnosis of analog circuit using quantum hopfield neural network," in *Proc. Chin. Control Decis., Conf.*, 2013, pp. 4238–4243.
- [9] H. Zhao, H. Liu, W. Hu, and X. Yan, "Anomaly detection and fault analysis of wind turbine components based on deep learning network," *Renew. Energy*, vol. 127, pp. 825–834, Nov. 2018.
- [10] Q. Ma, Y. He, and F. Zhou, "A new decision tree approach of support vector machine for analog circuit fault diagnosis," *Analog Integr. Circuits Signal Process.*, vol. 88, no. 3, pp. 455–463, 2016.
- [11] Z. Zhang, Z. Duan, L. Yuan, and Y. Long, "A new swarm-SVM-based fault diagnosis approach for switched current circuit by using kurtosis and entropy as a preprocessor," *Analog Integr. Circuits Signal Process.*, vol. 81, no. 1, pp. 289–297, 2014.
- [12] C. Zhang, Y. He, L. Yuan, W. He, S. Xiang, and Z. Li, "A novel approach for diagnosis of analog circuit fault by using GMKL-SVM and PSO," *J. Electron. Test.*, vol. 32, no. 5, pp. 531–540, Oct. 2016.
- [13] M. Tadeusiewicz and S. Hałgas, "A method for local parametric fault diagnosis of a broad class of analog integrated circuits," *IEEE Trans. Instrum. Meas.*, vol. 67, no. 2, pp. 328–337, Feb. 2018.
- [14] Q. Z. Zhou, Y. L. Xie, D. J. Bi, X. Xie, S. S. Xie, and X. F. Li, "Methodology and equipments for analog circuit parametric faults diagnosis based on matrix eigenvalues," *IEEE Trans. Appl. Supercond.*, vol. 24, no. 5, Oct. 2014, Art. no. 0601106.
- [15] A. S. S. Vasani, B. Long, and M. Pecht, "Diagnostics and prognostics method for analog electronic circuits," *IEEE Trans. Ind. Electron.*, vol. 60, no. 11, pp. 5277–5291, Nov. 2013.
- [16] Z. Liu, T. Liu, J. Han, S. Bu, X. Tang, and M. Pecht, "Signal model-based fault coding for diagnostics and prognostics of analog electronic circuits," *IEEE Trans. Ind. Electron.*, vol. 64, no. 1, pp. 605–614, Jan. 2017.
- [17] M. Khanlari and M. Ehsanian, "An improved KFCM clustering method used for multiple fault diagnosis of analog circuits," *Circuits Syst. Signal Process.*, vol. 36, no. 9, pp. 3491–3513, Sep. 2017.
- [18] A. Kumar and A. P. Singh, "Fuzzy classifier for fault diagnosis in analog electronic circuits," *ISA Trans.*, vol. 52, no. 6, pp. 816–824, 2013.
- [19] M. Tadeusiewicz and S. Hałgas, "A new approach to multiple soft fault diagnosis of analog BJT and CMOS circuits," *IEEE Trans. Instrum. Meas.*, vol. 64, no. 10, pp. 2688–2695, Oct. 2015.
- [20] M. Hu et al., "Soft fault diagnosis for analog circuits based on slope fault feature and BP neural networks," *Tsinghua Sci. Technol.*, vol. 12, pp. 26–31, Jul. 2007.