

## Split Ring Resonator Printed Microstrip Based Antenna array for Satellite and Radar Applications

R. Balapriya<sup>1</sup>, D. Sugumar<sup>2</sup>, Sangeetha Murugan<sup>3</sup>, Raghunath Mandipudi<sup>4</sup>, Prasanthi Kumari Nunna<sup>5</sup>, Angulakshmi M<sup>6</sup>, G.Nixon Samuel Vijayakumar<sup>7</sup> and Ajay Singh Yadav<sup>8</sup>

<sup>1</sup> Division of Mathematics, Saveetha Institute of Medical and Technical Sciences, SIMATS University, Chennai, Tamil Nadu.

<sup>2</sup> Department of ECE, Karunya Institute of Technology and Sciences (Deemed to be University), Coimbatore, Tamil Nadu.

<sup>3</sup> Department of Computer Science, Madanapalle Institute of Technology & Science, Madanapalle, Andhra Pradesh.

<sup>4</sup> Department of Electronics and Communication Engineering, Aditya University, Surampalem, Andhra Pradesh, India.

<sup>5</sup> School of Computer Sciences, UPES, Dehradun, Uttarakhand 248007, India.

<sup>6</sup> School of Computer Science Engineering and Information Systems, Vellore Institute of Technology, Vellore, Tamil Nadu

<sup>7</sup> Department of Physics, R.M.K.Engineering College, Kavaraipettai, Tamil Nadu 601206, India.

<sup>8</sup> Department of Mathematics, SRM Institute of Science and Technology, Delhi, Uttar Pradesh 201204, India.

Corresponding Author Email: [drbright.sa@gmail.com](mailto:drbright.sa@gmail.com)

<https://doi.org/10.14447/jnmes.v28i1.a03>

### ABSTRACT

**Received:** April 09-2024

**Accepted:** December 20-2024

#### **Keywords:**

*SRR, triband, Metamaterial, Satellite Communication, Radar.*

An article that presents a simple printed antenna array that includes a split ring resonator and a stub patch is offered here. A microstrip feed line is used to provide the antenna with power. The thin copper with a thickness of 0.0035 millimeters was used to construct the hexagonal SRR and the rectangular stub patch. Using CST Software, the antenna array is developed and then manufactured on a substrate made of FR4. Tri-band operation at 19.46 GHz, 29.16 GHz, and 40.14 GHz is attainable with the antenna array that has been presented, which is equipped with a split-ring resonator. The use of parametric analysis allows for the determination of the optimal dimensions for the proposed antenna dimensions. Validation of the performance of the proposed antenna is accomplished via the use of simulated scenarios. A presentation is made on return loss, surface current density, gain, directivity, three-dimensional radiation pattern, E-plane radiation pattern, and H-plane radiation pattern. Because of its small size, steady radiation pattern, high gain, ability to be applied across three bands, and excellent impedance matching, this antenna is particularly well-suited for use in satellite and radar communication communications.

## 1. INTRODUCTION

Satellite technology is playing an important part in the current communication and broadcasting applications that are being used nowadays. Both the earth station and the satellite must have an antenna in order for satellite technology to function properly. Satellite technology is a completely wireless technology. The utilization of enormous, cumbersome parabolic reflectors is commonplace at the earth station; however, this cannot be the case in space. The fact that the radio in the majority of the satellites is nonstatic presents still another obstacle. It is thus possible to make use of a low profile patch antenna in order to fulfill the aforementioned requirements. The properties of such an antenna that are desired include having a low profile, being compact in size, being inexpensive, being durable, and having multiband performance [1].

The conventional antennas are often used for applications that only involve a single band. Because satellite technology can accommodate a variety of applications and the space requirements of those applications, there is a growing need for multiband patch antennas that can operate in several bands. Because of its versatility, the multiband antenna [1-3] has emerged as a formidable contender for the Ku band application

[2]. Include single-layer patches, single patches, slot-etched patches, and stub loaded patches [4-10]. Both Fixed Satellite Service (FSS) and Direct Broadcast Service (DBS), both of which provide services in the K band, are considered to be the two most essential satellite services. Ku band, K band, and Ka-band are the three subgroups that make up the K band. Applications in the fields of satellites, short-range communications, and radar make extensive use of these bands. In the paper [11], it is claimed that a dual-band antenna would handle both the 5G and WiFi applications. In reference [12], a fractal geometry is shown for the Ku-band application. In reference [13], a triple-band antenna array that covers the C, X, and Ku bands is presented. In reference [14], a triple-band antenna with a circular disc as the radiating element is used for applications in the ISM, WiMax, and UMTS bands. It is proposed in [15] that an X-shaped radiating element that has been etched with five rectangular holes would function in the K band with three resonances. For the C, X, and Ku bands, a rectangular patch with a U-shaped slot is suggested in [16], and a hexagonal patch is proposed in [17]. In [18] and [19], the defective patch and ground are suggested for use in the multiband application. For the Ku band, researchers have suggested a probe-based multilayer antenna in [20-21], a reflectarray in [22], a planar patch array in [23], and a hexa-

triangular fractal structure in [24]. The majority of the antennas described in the aforementioned literature have a complicated construction, only support a single band, and are difficult to fabricate. As a result, the metamaterial structures [25-32] are carved alongside the patch antenna in order to improve the properties of the patch.

Negative permittivity and permeability are characteristics that are shown by metamaterials, which are artificial structures created by humans. In the event that all of these occurrences take place simultaneously, the result is a double negative medium that has a negative refractive index quality. In [25], an ELC-based circular monopole is presented for the tri-band operation, which encompasses wireless communication systems operating at lower frequencies. By combining both a split-ring resonator and its dual component, the rectangular offset feed monopole described in [26] is able to demonstrate an eight-band functioning. In [27], a rectangular monopole with complementary split resonator was etched in the greatest surface current zone. This region, in turn, encompasses the WLAN and WiMAX applications. In reference number 33, numerous split-ring resonators are loaded, and in reference number 34, a fishnet-shaped NZIM array is suggested for the purpose of enhancing gain. Although the metamaterial is capable of producing multiband characteristics, the suggested structure has a number of drawbacks, including a relatively low gain, an unstable radiation pattern, and a complicated design. These drawbacks contribute to the structure's complexity.

This work presents an antenna array for K band applications that is inspired by metamaterials and spans all regions of the Ku, K, and Ka bands. The goal of this research is to overcome the disadvantage that was described before. All satellite and RADAR services are provided via the band that is described above. Further the study is arranged as follows: in section 2, the design technique of the SRR inspired microstrip patch array is described, and followed by the parametric analysis of the important parameters in section 3. In part 4, the findings of the suggested antenna are examined, and in section 5, the paper is brought to a close.

## 2. DESIGN OF METAMATERIAL SRR INSPIRED MICROSTRIP ARRAY

For the purpose of the K band application, the SRR printed microstrip patch array is suggested in this current study. The proposed antenna has three resonance frequencies in the K band: 19.46 GHz, 29.16 GHz, and 40.14 GHz. These frequencies are determined by the K band. The structure that is being suggested encompasses the Ku, K, and Ka bands, which are used by the satellite as well as the majority of RADAR applications. The originality of the suggested antenna lies in the fact that it covers all three portions of the K band, despite its smallest size and simple construction. This is something that is not available in the existing literature. Validation of the suggested antenna is accomplished by the use of simulated data, which include return loss, voltage standing wave ratio (VSWR), surface current distribution, radiation pattern, gain, and directivity. The dimensions of the proposed antenna are 20 millimeters by 20 millimeters by 1.6 millimeters. Because of its compact and straightforward construction, as well as its steady radiation pattern, the suggested antenna array has multiband characteristics, which

make it more significant than the antenna that has been described in the literature.

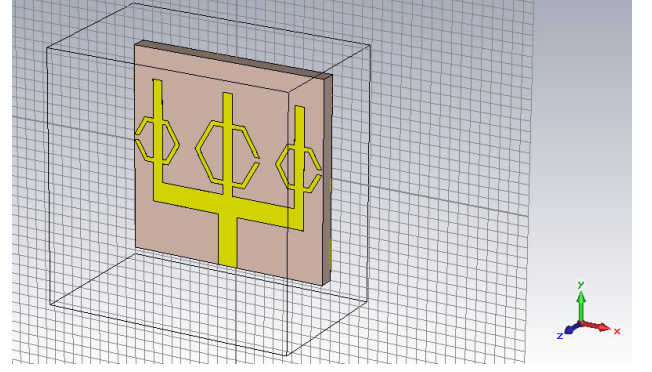

**Figure 1** The CST EM studio Design Environment proposes an SRR-inspired antenna array

The equation below designs the antenna.

$$W = \frac{c}{2f_r} \sqrt{\frac{2}{\epsilon_r + 1}} \quad (1)$$

$$L = \frac{c}{2f_r \sqrt{\epsilon_{eff}}} - 2\Delta L \quad (2)$$

$$\epsilon_{eff} = \frac{\epsilon_r + 1}{2} + \frac{\epsilon_r - 1}{2} \left[ 1 + \frac{12h}{W} \right]^{-1} \quad (3)$$

$$\Delta L = 0.412h \frac{(\epsilon_{eff} + 0.3) \left( \frac{W}{h} + 0.264 \right)}{(\epsilon_{eff} - 0.258) \left( \frac{W}{h} + 0.8 \right)} \quad (4)$$

The CST EM studio was used in the process of designing the antenna that is recommended in this article. The antenna is constructed on a base that is fire retardant, which is a 4. In terms of thickness, the substrate measures 1.6 millimeters, while the conducting material that is printed on top of the substrate measures around 0.035 millimeters. There are two different configurations of the antenna: ant a and ant b. Figure 1 depicts the antenna that was developed to be used in the electromagnetic environment of CST studio. A simple microstrip rectangular patch serves as the seed antenna in this design, and it is accompanied by three stubs that serve as patches. Following this, the split ring resonator is printed beside the stub in order to provide the desired improvement in impedance bandwidth. The SRR are positioned in the area of the stub that experiences the highest surface current. The suggested antenna is capable of operating in the Ka, K, and Ku bands, with corresponding frequencies of 19.46 GHz, 29.16 GHz, and 40.14 GHz. The development of the suggested antenna is seen in figure 2, which can be found here. The most significant distinction between the two phases is the printed SRR. Ant an is a straightforward patch consisting of three stubs, while Ant b is a patch array consisting of three stubs with SRR. There is a presentation of the suggested antenna together with its parameters in figure 3, and the values for those parameters are shown in table 1.

In order to determine the inductance  $L_{SRR}$  and capacitance  $C_{SRR}$  of the SRR, equation 5 and equation 6 are used with regard to the calculation.

$$L_{SRR} = 4 * \mu_0 * [l - (N - 1)(w + s)] * \left[ \ln \left( \frac{0.98 * [l - (N - 1)(w + s)]}{(N - 1)(w + s)} \right) + \left( \frac{1.84 * [l - (N - 1)(w + s)]}{(N - 1)(w + s)} \right) \right] \quad (5)$$

$$\frac{N-1}{2} * [2l - (2N - 1)(w + s)] * \epsilon_0 * \left( \frac{K(\sqrt{1-k^2})}{K(k)} \right) \quad (6)$$

$$\text{where } k = \frac{s}{2w+s}$$

$$F = \frac{1}{2\pi\sqrt{L_{SRR}C_{SRR}}} \quad (7)$$

where is the  
 The number of rings is denoted by the letter N.  
 W is the width of the slot.  
 A is the length that is average,

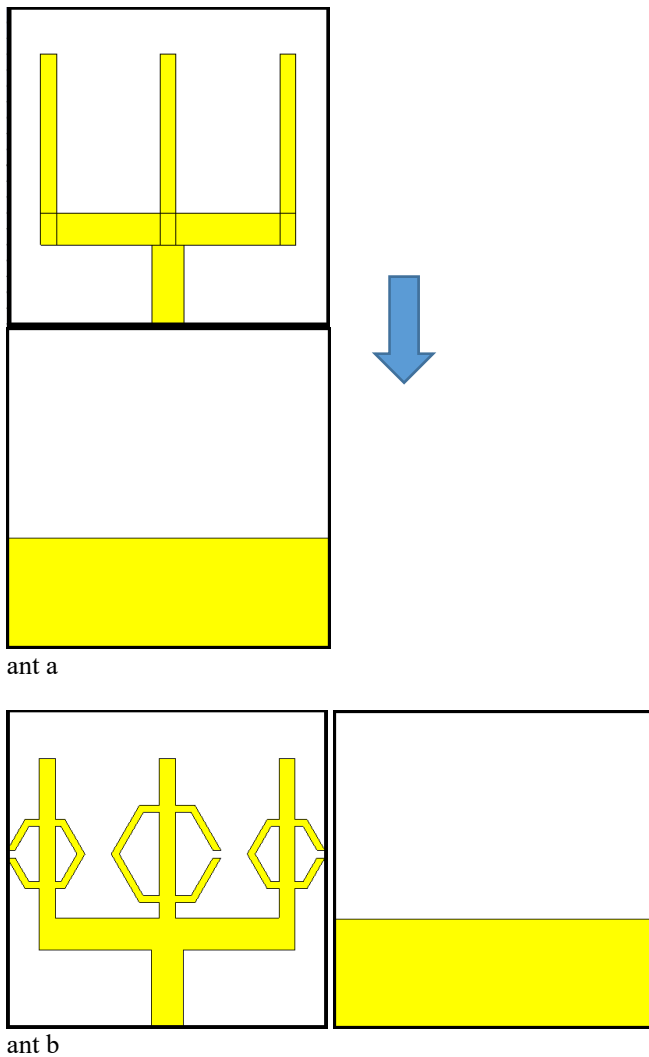

Figure 2 SRR-inspired antenna array evolution

1 mm x 1 mm is the size of the rectangular stubs that make up the first ant a, which is a basic patch array. Three stubs are fed using a straightforward microstrip feed that is matched to a resistance of fifty ohms. Two dual band resonances are being produced by the antenna stub patch array that has been constructed. These resonances range from 22.80 GHz to 27.78 GHz and 29.32 GHz to 35.80 GHz. Dual resonance occurs at 23.22 GHz and 26.35 GHz in the first band, whereas resonance occurs at 33.22 GHz in the second band with the first band. In terms of its impedance bandwidth, the Ant A has a bandwidth of 6482 MHz and a bandwidth of 4981 MHz where it operates in its respective operational bands. The antenna, on the other hand, radiates outwardly at the K band, and the impedance at the operational frequency is less matched. It is necessary to print the split ring resonator in conjunction with the stub in order to get the desired results of improving impedance matching and producing operational bands at the Ka and Ku bands. The SRR is printed in the region of the stub that has the highest surface current, which in turn causes the SRR to have an effect. As a result, the suggested antenna with SRR has

three different operating bands and has excellent impedance matching. The frequency range that Ant B operates at ranges from 18.91 GHz to 20.30 GHz, 22.84 GHz to 36.41 GHz, and 38.18 GHz to 50.80 GHz.

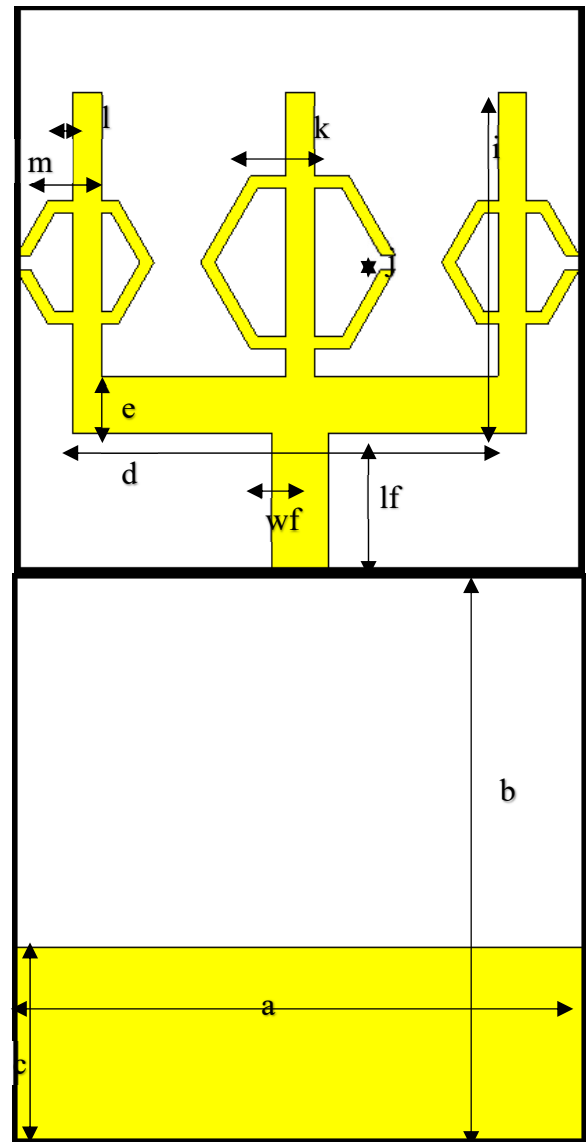
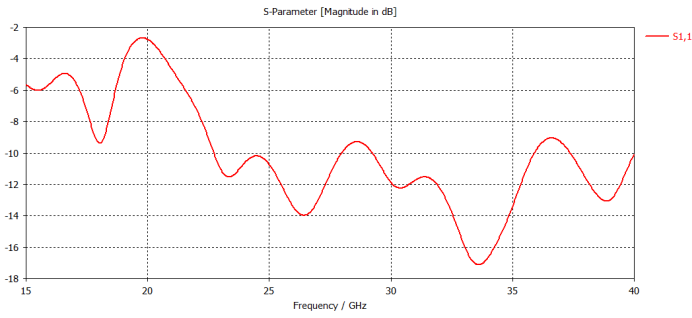

Figure 3: SRR-inspired antenna array parameters

SRR-inspired antenna array parameters in mm are shown in Table 1.

a	b	c	wf	lf	d	e
20	20	7	2	5	16	2
i	j	k	l	m	h	t
12	0.5	3.5	1	2.5	1.6	0.0035



The antenna A return loss curve is shown in Figure 4.

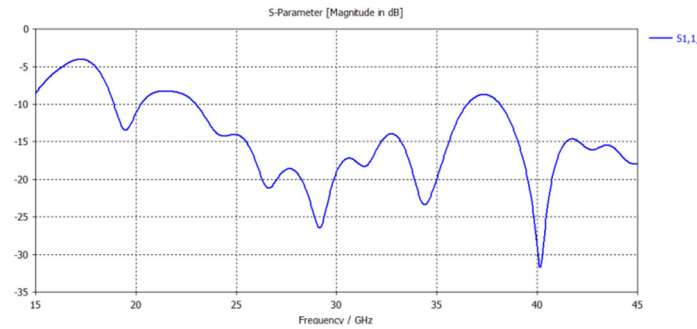

The antenna B return loss curve is shown in Figure 5.

### 3. PARAMETRIC ANALYSIS

The length of the ground is changed in increments of one millimeter, ranging from ten millimeters to twelve millimeters. It is noticed from the figure that the value of 1 mm has high impedance matching in all of the resonant bands, and as a consequence, it is selected for the final design. The findings of the analysis are displayed in figure 6, which can be found here. The height of the substrate is also changed in increments of 0.4 millimeters, ranging from 0.4 millimeters to 1.6 millimeters.

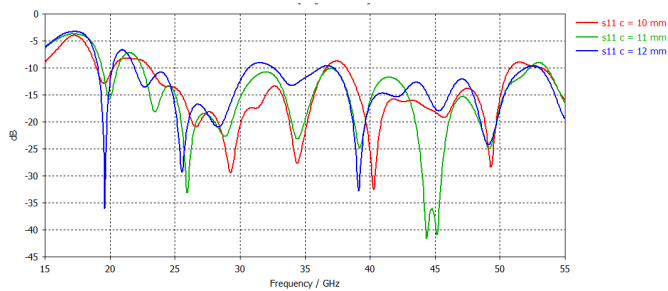

Figure 6 S11 for varied C (ground length) values

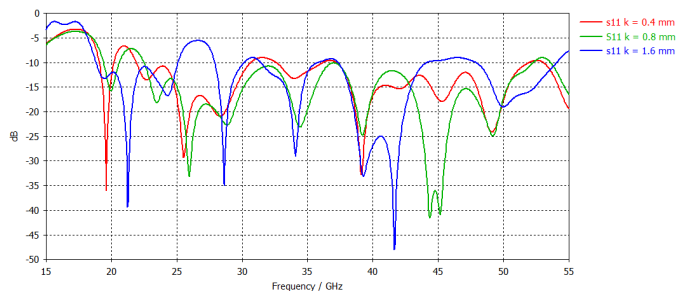

Figure 7 S11 for varied K values.

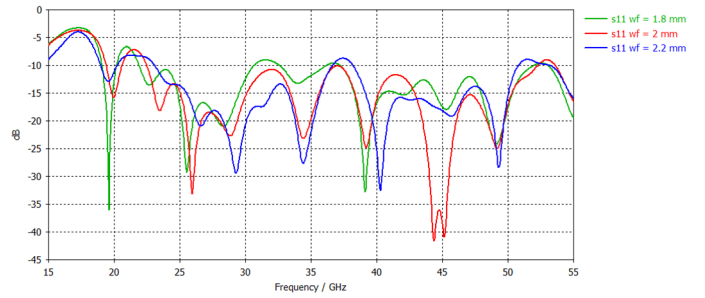

Figure 8 S11 for different wf values.

It has been found that the antenna array is capable of having excellent impedance bandwidth and triband resonance when the substrate height is 1.6 millimeters. The findings are provided in figure 7, and it can be seen that this is not the case. It is for this reason that the substrate height of 1.6 millimeters is selected for the manufacturing process. Finally, the feed width is evaluated, and it is discovered that a feed width of 2 millimeters has adequate impedance matching at the resonant frequencies. This is the conclusion reached when the analysis continues. Because of this, it will be used in the final design. The next stage is to do an examination of the feed width by adjusting the value of wf in increments of 0.2 mm, ranging from 1.8 mm to 2.2 mm. a representation of the findings may be seen in figure 8.

### 4. RESULT AND DISCUSSION

Based on this distribution, we are able to draw the conclusion that the implementation of the SRR is the individual accountable for the multiband operations and the enhancement of bandwidth. The proposed antenna has a band width of 1443 MHz, 13658 MHz, and 12845 MHz at 19.46 GHz, 29.16 GHz, and 40.14 GHz, respectively. These frequencies correspond to the relevant frequencies.

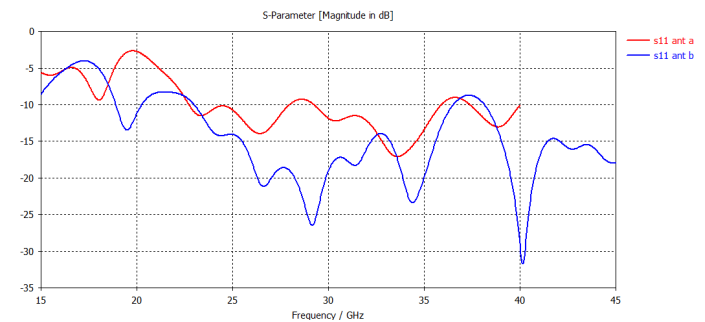
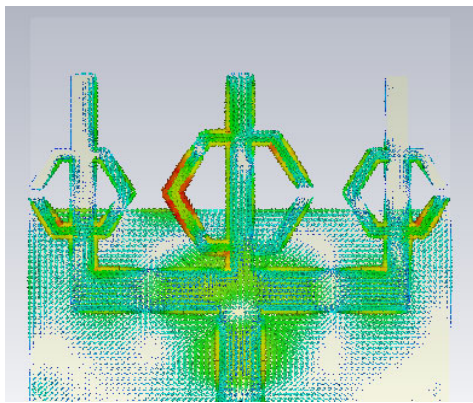
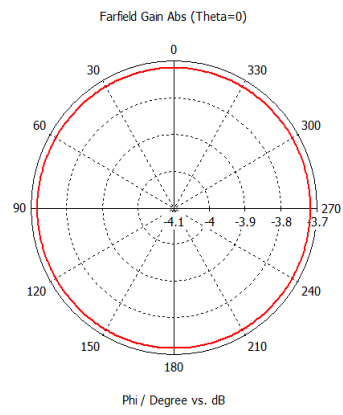

Figure 9. A/B antenna return loss map



a) 19.46 GHz



— farfield (f=19.46) [1]

Frequency = 19.46  
Man lobe magnitude = -3.72 dB

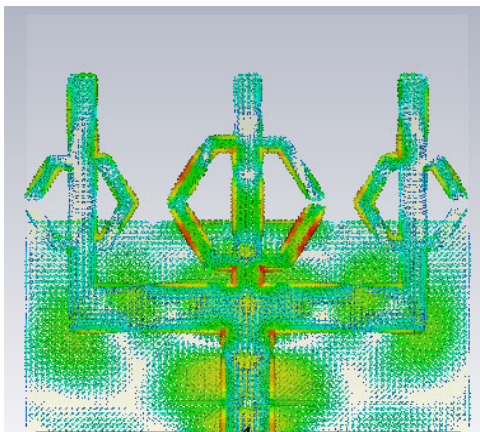

b) 29.16 GHz

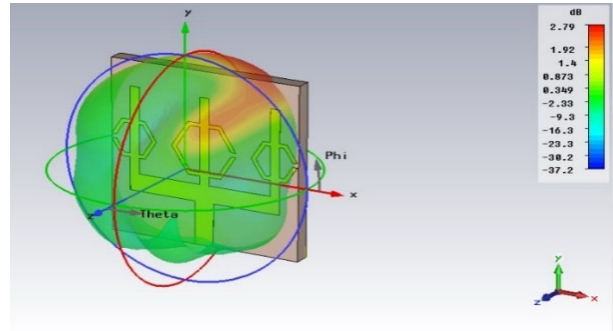

a) 19.46 at GHz

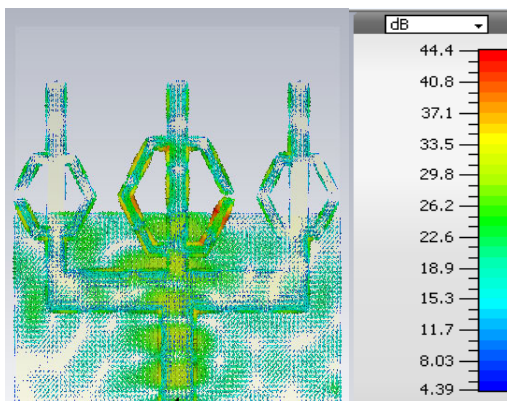

c) 40.14 gigahertz

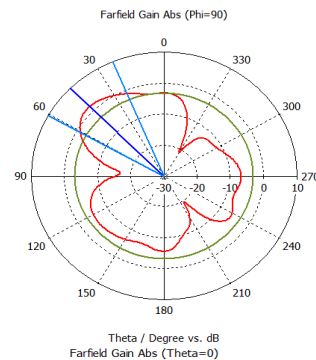

— farfield (f=29.16) [1]

Frequency = 29.16  
Man lobe magnitude = 1.74 dB  
Man lobe direction = 45.0 deg.  
Angular width (3 dB) = 38.2 deg.  
Side lobe level = -4.9 dB

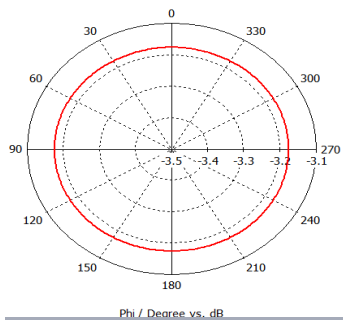

— farfield (f=29.16) [1]

Frequency = 29.16  
Man lobe magnitude = -3.18 dB

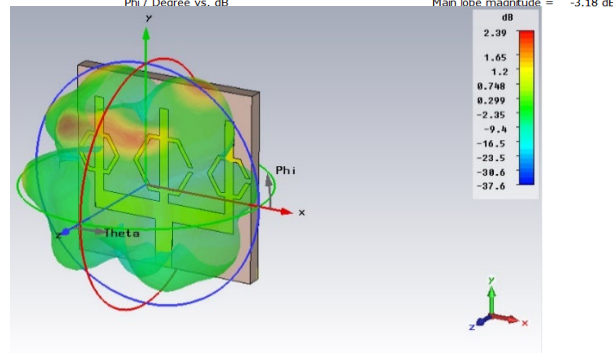

b) 29.16 at GHz

**Figure 10: Surface current distribution at various resonant frequencies**

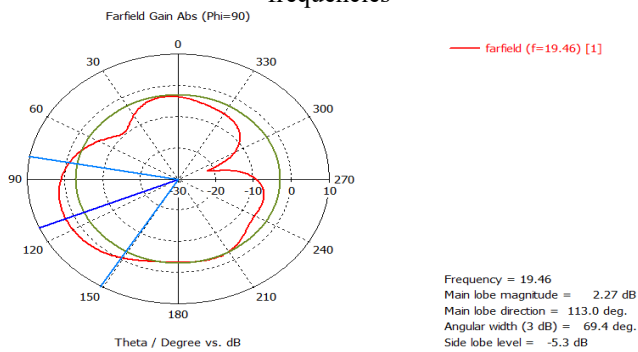

— farfield (f=19.46) [1]

Frequency = 19.46  
Main lobe magnitude = 2.27 dB  
Main lobe direction = 113.0 deg.  
Angular width (3 dB) = 69.4 deg.  
Side lobe level = -5.3 dB

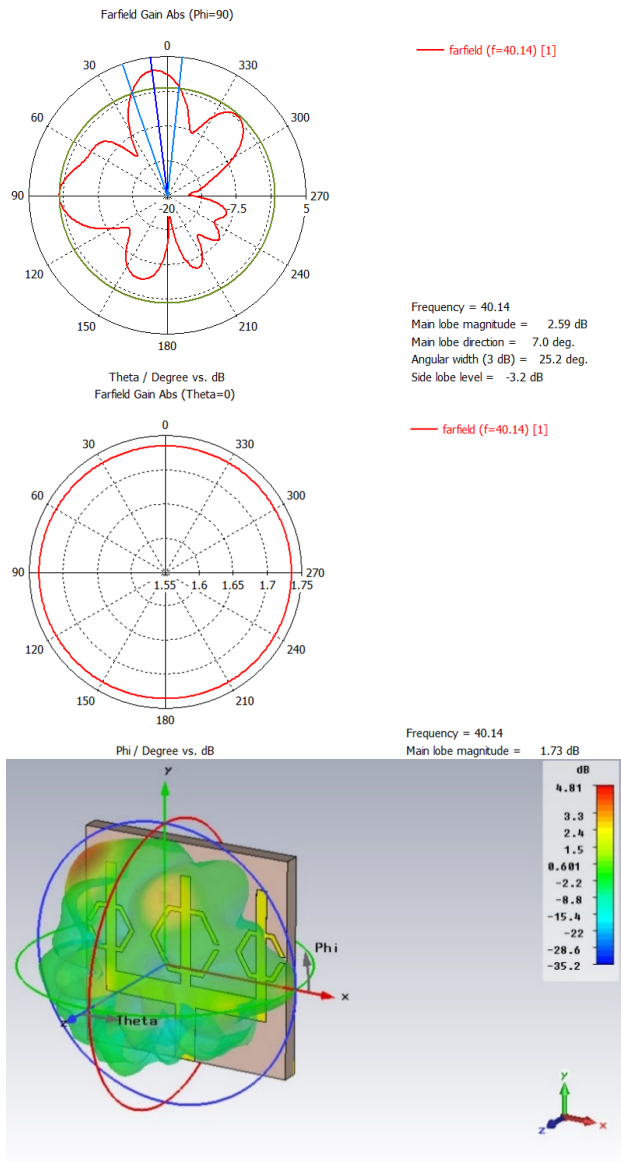

c) 40.14 at GHz

Figure 11: 3D, E, and H radiation patterns at various resonating frequencies.

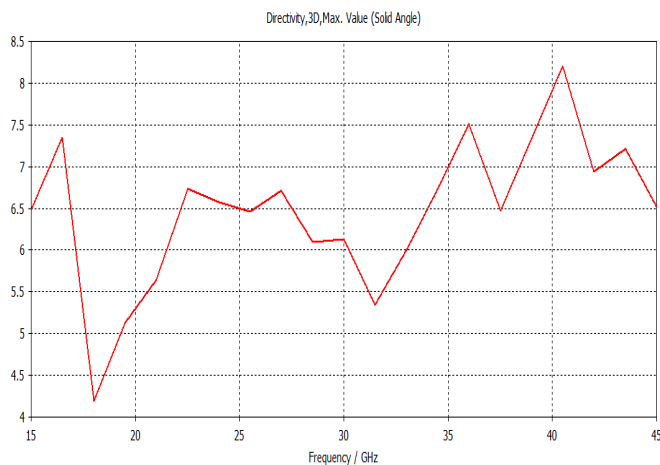

Figure 12 SRR-inspired antenna array directivity vs. frequency

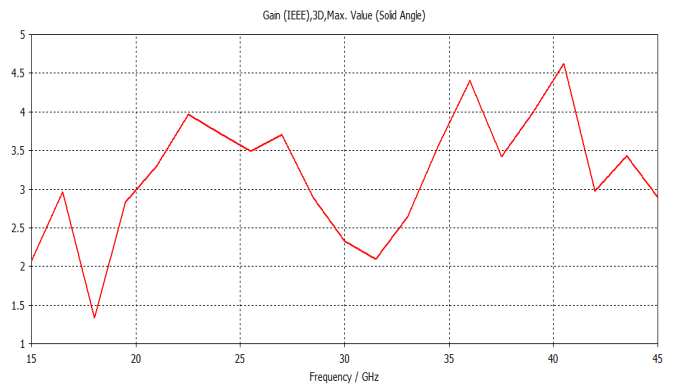

Figure 13 SRR-inspired antenna array frequency/gain

## 5. CONCLUSION

Simple SRR-inspired patch antenna array that is tri-band is presented for use in applications that need tri-band operation. It is constructed on a FR4 substrate that measures 20 millimeters by 20 millimeters. It is possible to activate the multiband capabilities by printing the SRR in conjunction with the rectangle stub radiating element. Tri-band operation is used by the antenna, which has resonance frequencies of 19.46 GHz, 29.16 GHz, and 40.14 GHz. The authenticity of the antenna is established with the assistance of the simulated outcomes of s11 and the radiation pattern. Additionally, the paper presents the surface current distribution of the suggested antenna, as well as the predicted gain and directivity of the configuration. This antenna is a good choice for satellite and radar communication because of its straightforward design, small size, moderate gain, and multiband performance in the K band of the electromagnetic spectrum.

## REFERENCE

- [1] Wong, K. L., Compact and Broadband Microstrip Antennas, Vol. 168, John Wiley & Sons, 2004.
- [2] Kumar, G. and K. Ray, Broadband Microstrip Antennas, Artech House, 2002.
- [3] James, J. R. and P. S. Hall, Handbook of Microstrip Antennas, 28, IET, 1989.
- [4] Vijayvergiya, P. L. and R. K. Panigrahi, "Single-layer single-patch dual band antenna for satellite applications," IET Microwaves, Antennas and Propagation, Vol. 11, No. 5, 664–669, 2016.
- [5] Kouhalvandi, L., S. Paker, and H. B. Yagci, "Ku-band slotted rectangular patch array antenna design," 2015 23th IEEE Signal Processing and Communications Applications Conf. (SIU), 447–450, 2015.
- [6] Parikh, H., S. V. Pandey, and M. Sahoo, "Design of a modified E-shaped dual band patchantenna for Ku band application," CSNT, 49–52, Rajkot, India, 2012.
- [7] Saini, G. S. and R. Kumar, "A low profile patch antenna for Ku-band applications," International Journal of Electronics Letters, 1–11, 2019.
- [8] Dubey, S. K., S. K. Pathak, and K. K. Modh, "High gain multiple resonance Ku band microstrip patch antenna," IEEE Applied Electromagnetics Conf. (AEMC), 1–3, 2011.
- [9] Prasad, P. C. and N. Chattoraj, "Design of compact ku band microstrip antenna for satellite communication,"

- 2013 Int. Conf. Communications and Signal Processing (ICCSP), 196–200, 2013.
- [10] Sayed, A., R. S. Ghonam, and A. Zekry, “Design of a compact dual band microstrip antenna for Ku-band applications,” *International Journal of Computer Applications*, Vol. 115, No. 13, 11–14, 2015.
- [11] Mao, Y., S. Guo, and M. Chen, “Compact dual-band monopole antenna with defected ground plane for Internet of things,” *IET Microwaves, Antennas & Propagation*, Vol. 12, No. 8, 1332–1338, 2018.
- [12] Nguyen Thi, T., K. C. Hwang, and H. B. Kim, “Dual-band circularly-polarised Spidron fractal microstrip patch antenna for Ku-band satellite communication applications,” *Electronics Letters*, Vol. 49, No. 7, 444–445, 2013.
- [13] Khare, A. and R. Nema, “Triple band parasitic array antenna for C-X-Ku-band application using out-of-phase coupling approach,” *International Journal of Antennas and Propagation*, 2014.
- [14] Mathew, S., R. Anitha, U. Deepak, C. K. Aanandan, P. Mohanan, and K. Vasudevan, “A compact tri-band dual-polarized corner-truncated sectoral patch antenna,” *IEEE Transactions on Antennas and Propagation*, Vol. 63, No. 12, 5842–5845, 2015.
- [15] Samsuzzaman, M., M. T. Islam, N. Misran, and M. M. Ali, “Dual band X shape microstrip patch antenna for satellite applications,” *Procedia Technology*, Vol. 11, 1223–1228, 2013.
- [16] Naghar, A., O. Aghzout, M. Essaaidi, A. Alejos, M. Sanchez, and F. Falcone, “Ultra wideband and tri-band antennas for satellite applications at C-, X-, and Ku bands,” *Proceedings of 2014 Mediterranean Microwave Symposium (MMS2014)*, 1–5, IEEE, December 2014.
- [17] Dhakad, S. K. and T. Bhandari, “A hexagonal broadband compact microstrip monopole antenna for C band, X band and Ku band applications,” *2017 International Conference on Computing, Communication and Automation (ICCCA)*, 1532–1536, IEEE, May 2017.
- [18] Baudha, S. and V. Dinesh Kumar, “Corner truncated broadband patch antenna with circular slots,” *Microwave and Optical Technology Letters*, Vol. 57, No. 4, 845–849, 2015.
- [19] Gupta, A., H. D. Joshi, and R. Khanna, “An X-shaped fractal antenna with DGS for multiband applications,” *International Journal of Microwave and Wireless Technologies*, Vol. 9, No. 5, 1075–1083, 2017.
- [20] Nguyen Thi, T., K. C. Hwang, and H. B. Kim, “Dual-band circularly-polarised Spidron fractal microstrip patch antenna for Ku-band satellite communication applications,” *Electronics Letters*, Vol. 49, No. 7, 444–445, 2013.
- [21] Lai, H. W., D. Xue, H. Wong, K. K. So, and X. Y. Zhang, “Broadband circularly polarized patch antenna arrays with multiple-layers structure,” *IEEE Antennas and Wireless Propagation Letters*, Vol. 16, 525–528, 2016.
- [22] Deng, R., S. Xu, F. Yang, and M. Li, “A single-layer high-efficiency wideband reflectarray using hybrid design approach,” *IEEE Antennas and Wireless Propagation Letters*, Vol. 16, 884–887, 2016.
- [23] Huang, J., W. Lin, F. Qiu, C. Jiang, D. Lei, and Y. Jay Guo, “A low profile, ultra-lightweight, high efficient circularly-polarized antenna array for Ku band satellite applications,” *IEEE Access*, Vol. 5, 18356–18365, 2017.
- [24] Darimireddy, N. K., R. R. Reddy, and A. M. Prasad, “A miniaturized hexagonal-triangular fractal antenna for wide-band applications [Antenna Applications Corner],” *IEEE Antennas and Propagation Magazine*, Vol. 60, No. 2, 104–110, 2018.
- [25] Sam, Prasad Jones Christydass, and N. Gunavathi. (2020). A tri-band monopole antenna loaded with circular electric-inductive-capacitive metamaterial resonator for wireless application. *Applied Physics A* 126, no. 10.
- [26] Samuel Prasad Jones Christydass and Nagarajan Gunavathi. (2021). Octa-Band Metamaterial Inspired Multiband Monopole Antenna for Wireless Application. *Progress In Electromagnetics Research C*, Vol. 113, 97-110.
- [27] Samuel Prasad Jones Christydass and Nagarajan Gunavathi. (2021). Dual-Band Complementary Split-Ring Resonator Engraved Rectangular Monopole for GSM and WLAN/WiMAX /5G Sub-6 GHz Band (New Radio Band). *Progress In Electromagnetics Research C*, Vol. 113, 251-263.
- [28] Dr.S.Shanthi, Dr. T. Jayasankar, Prasad Jones Christydass, Dr. P. Maheswara Venkatesh. (2019). Wearable textile antenna for GPS application. *International Journal of Scientific & Technology Research Volume 8. Issue 11*.
- [29] Dr.A.Kavitha, S.Prasad Jones Christydass, J.Silamboli, Dr.K.Premkumar, Dr.A.Nazar Ali. (2020). Metamaterial Inspired Triple Band Antenna for Wireless Communication. *International Journal of Scientific & Technology Research Volume 9, Issue 03*.
- [30] N.Ramya, M.Sujatha, T.Jayasankar, Prasad Jones Christydass. (2020). Metamaterial Inspired Circular Antenna with DGS for Tetra Band Application. *International Journal of Control and Automation Vol. 13, No. 2, pp. 877 – 882*.
- [31] J. Vijayalakshmi, S B Vinay Kumar, Radhika Baskar, Prasad Jones Christydass. (2020). Design of Circular Antenna with Codirectional CSRR for Penta Band Applications. *International Journal of Advanced Science and Technology*, Vol. 29, No. 03, pp. 9063 – 9072.
- [32] Christydass, S. Prasad Jones, J. Suganthi, S. Kavitha, and R. Yuvaraj. (2021). Ring monopole antenna for Tera-Hertz application”, *Materials Today: Proceedings* 45, 1827-1833.
- [33] Arora C, Pattnaik SS, Baral RN (2016) Metamaterial superstrate for performance enhancement of microstrip patch antenna array. In: 3rd international conference on signal processing and integrated networks. IEEE, Noida, India, pp 3–7.
- [34] Bhattacharjee D et al (2015) Gain enhancement of a slot antenna with a metamaterial superstrate structure. In: Applied electromagnetics conference. IEEE, Guwahati, India, pp 6–7.